

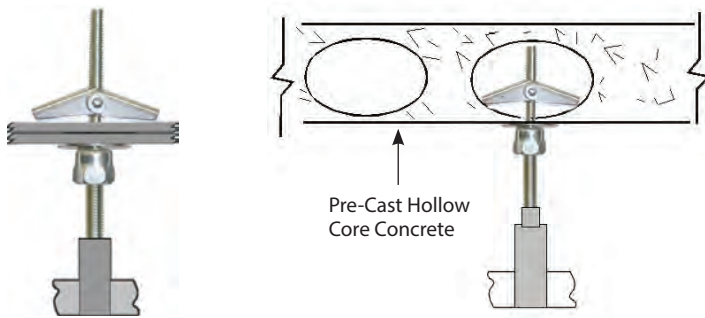

## SAMMYS TOGGLE™ – Application



## INSTALLATION STEPS

1. Pre-drill a 5/8" hole with a regular drill or hole saw.
2. Insert SST screw into #14 black nut driver. With wing nut and washer on bolt, insert wing nut through surface, and begin installation.
3. When bolt is secure and nut driver spins free, stop drill motor and remove.

Rod Size	Part Number	Model	Screw Description	Ultimate Pullout (lbs)	Box Qty	Case Qty	Nut Driver
3/8"	8064925	SST 30	1/4 x 3"	450 (Lath & Plaster) 404 (2 Layers 5/8 Drywall)	25	125	#14 Black Part # 8113910

## DEKTITE® PIPE FLASHING – Application

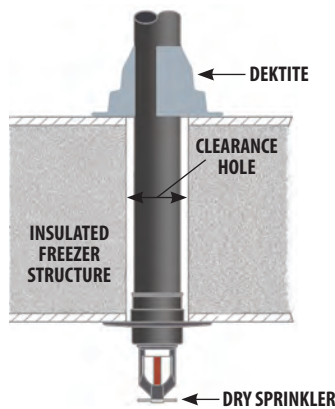

**STAY UP TO CODE!**  
with a quicker, more efficient way to flash your refrigeration/freezer units.

## PRODUCT FEATURES

- Complies with NFPA 13 Code Changes.
- Flashing for dry pendant sprinklers subject to extreme temperature change.
- One piece construction is easy to install.
- Pipe diameter markings ensure accurate fit.
- EPDM temperature range of -65°F to +250°F.

Part Number	Description	Pipe Outside Diameter	Dektite Base Diameter	Dektite Height	Box Qty
4003910	1	1/4" - 2"	4-3/4"	3"	10
4004910	2	1-3/4" - 3-1/4"	6-1/4"	4"	10